

## Push Button Switches

KLS7-527-201NGB Bold green light 220v Self lock, Opening diameter=20mm



### Description:

Electrical rating:12A 125VAC/250VAC VDE:10(4)A250VAC  
 Contact resistance:<20mΩ  
 Insulation resistance:>1000MΩ(500DC between open contacts)  
 Dielectric strength:>1500V 1 minute  
 Mechanical life:>30000 Cycles  
 Electrical life:>10000 Cycles  
 Temperature rise at hte terminal:Max.30°C  
 Solder ability of terminal:Max350°C,3S

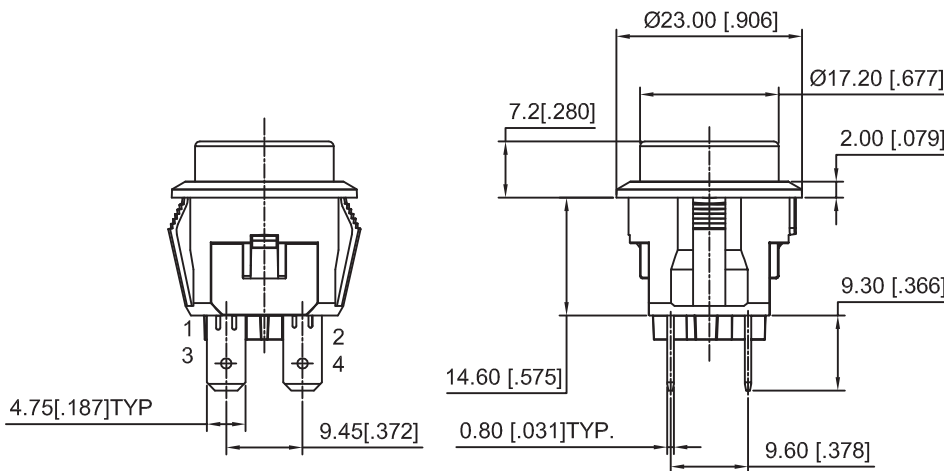
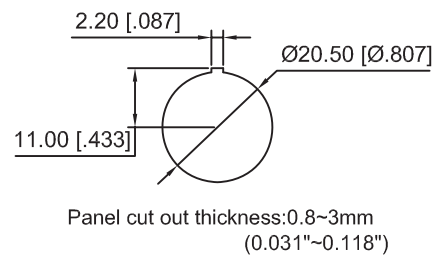
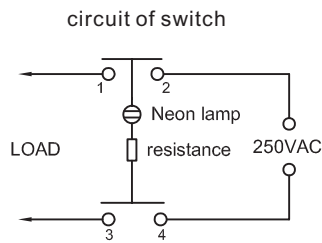
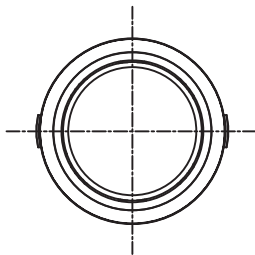

CIRCUIT DPST

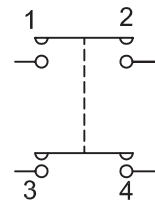

## ORDER INFORMATION

**L-KLS7-527-201NGB**

