

RoHS Compliance

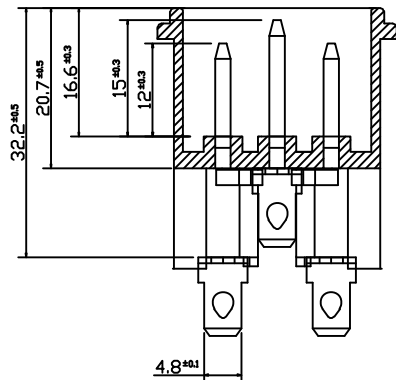
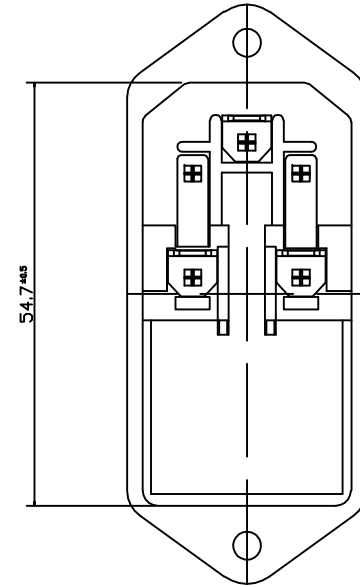
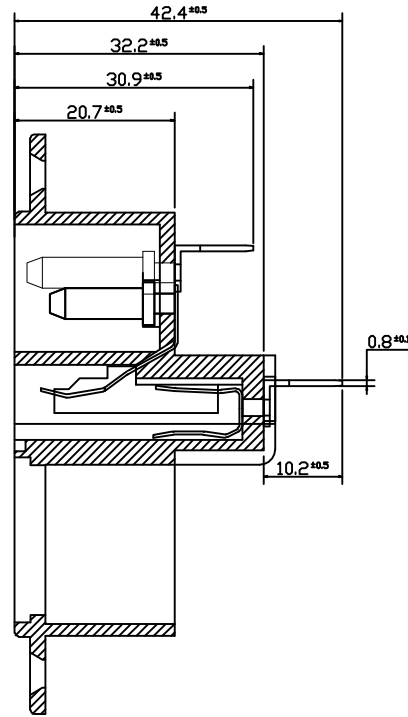
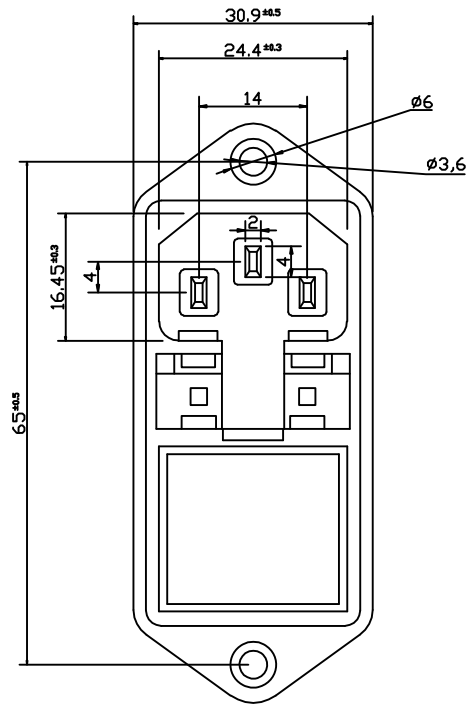

PANEL CUT-OUT

Electrical Characteristics:
 Rating: 10A 250V AC
 Insert and Extract Force: 1.36kgf ~ 6.8kgf
 Terminal Strength: ≥80N
 Operating Life: ≥5000 Cycles
 Withstand Voltage: Between all terminals: 2500VAC (50-60Hz) 1Min
 terminals to Base: 3750V AC (50-60Hz) 1Min
 Leakage Current: 1mA
 Insulation Resistance: ≥100MΩ 500V DC

ANGLE TOLERANCE	PROJECTION	Description:	AC Power Sockets/AC Plugs	
±3°				
GENERAL TOLERANCE	UNITS	mm	KLS P/N:	L-KLS1-AS-303-10
x.x ±0.30	SHEET SIZE	A4		
x.xx ±0.20	Draw:	Daniel	2020-11-11	NingBo KLS ELECTRONIC CO.,L TD.
x.xxx ±0.10	Check:	Daniel	2020-11-11	